



KONICA MINOLTA

MINIMISE ALL. MAXIMISE ALL.

bizhub PRESS

C1100 / C1085



Giving Shape to Ideas

A New Evolution in Digital Printing

bizhub PRESS 
C1100 / C1085



High-Potential Digital Press

For customers considering updating their colour on-demand machines to realise even higher levels of service through both “quality” and “speed” to keep up with dramatic increases in the volume of orders and heightened demand for quality.

The appearance of DTP has triggered the acceleration of data digitalisation.

Technologies such as on-demand printing and electronic publishing are steadily becoming a reality.

Rather than the needs for high-volume printing of standardised information, the demand for on-demand printing capable of printing small quantity print jobs or variable data as needed, has grown dramatically.

In addition, the rapid spread of tablet PCs has spurred the unrelenting transition from paper to electronic media.

From paper to electronic media, and electronic media to paper.

The fusion of paper and electronic media has further increased the need for on-demand printing.

bizhub PRESS C1100/C1085 has stepped into the spotlight with its high productivity on-demand printing capabilities.

Harmonics Concept

Konica Minolta concepts comprise the goals of “Symbiosis in the form of reciprocal contributions to offset business,” “Expanding the scope of orders for applications” and “Wide-ranging and steady implementation of printing missions.” The “High-Potential Digital Press” has been launched to achieve these Konica Minolta concepts and support business expansion.

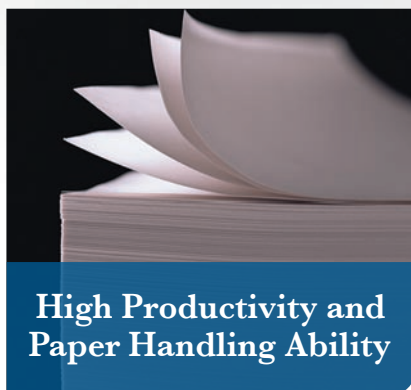

- 100% productivity ranging from thin to thick paper
- Capable of handling duplex printing of a maximum of 350gsm paper



- Major improvements in colour stability during continuous print
- Expanded colour gamut realised by Simitri HD^F Toner



- Improved connectivity to offset workflow
- Improved operability by the main body panel

High Productivity

High Productivity and Paper Handling Ability

High-Potential Digital Press meets the needs for high-speed processing, high-volume production and continuous operation for orders of widely-varied print jobs. Not only high productivity, High-Potential Digital Press offers the ability to handle an expanded range of paper types and is capable of stable, high-speed output of thin coated paper flyers to thick paper pop, for example, traditionally regarded as being difficult to handle.



High-productivity capable of High-volume processing of a Wide Diversity of Jobs

Capable of handling paper ranging from 55gsm to 350gsm, bizhub PRESS C1100/C1085 realises 100% productivity. Large volumes of highly-varied papers can be handled to realise print products with short lead time. Stable production performance makes it possible to meet tight deadlines and supports the customer's business expansion.

100% Productivity

The synergy between the newly-designed large-diameter upper fusing system and Simitri HD^F Toner enables realisation of high speed printing of 100 sheets*/minute for paper weights of 55-350gsm. Improvements to the fusing roller have enabled expansion of the fusing belt contact area, realising greater optimisation to achieve speedy and homogenised heat transfer. *For A4 horizontal, C1100 (Speed for C1085: 85 sheets/minute)

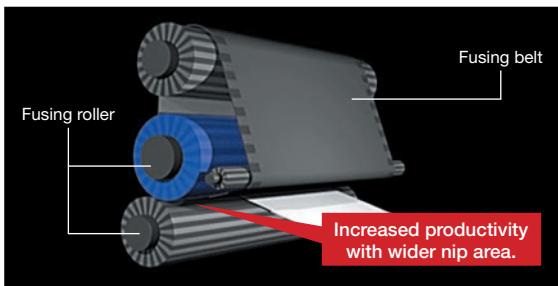

Setting of large Volumes of Highly-varied Paper Types

With all options mounted, the paper feeding system can be expanded to handle 9 highly-varied paper types with a maximum input paper capacity of 13,890 sheets and maximum output capacity of 10,000 sheets. Tasks such as paper replenishment and removal can be performed during printing, enabling the processing of high-volume catalog jobs with ease.

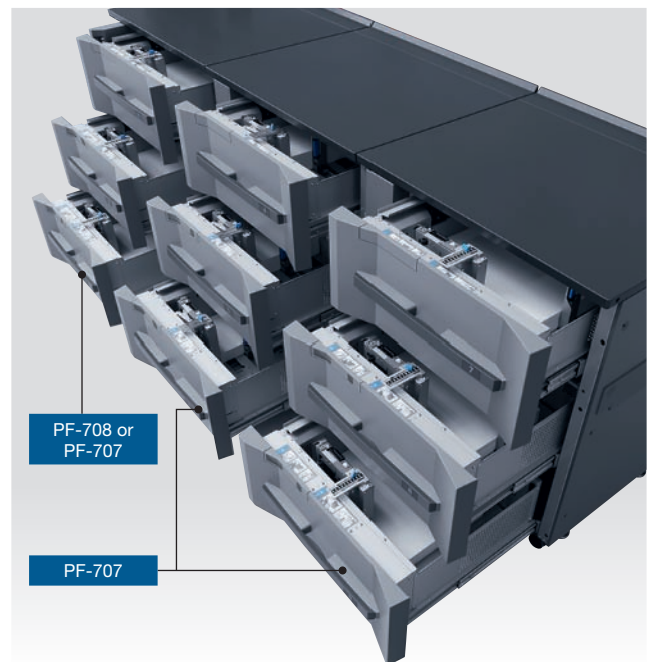

Newly-developed Suction Feeder

An air suction paper-feed belt is incorporated in the [PF-707/PF-708]* paper-feed unit. In addition to air blown from the sides by the air-assist function, an air stream is also applied from the front to separate the paper, which is then adhered to the suction belt for conveyance. Optimised air control and improved bonding area during paper feed ensures more stable paper feed for thick coated paper. *Optional

Superiority of Suction Type Paper Feed

- Resistance to the effects of paper dust prevents miss-feeding.
- The long maintenance cycle ensures reduced down time.

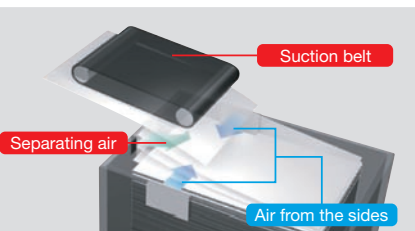

*If two or more PF-707, 708 units are installed in a row, FA-502 must be connected as a bypass option.
*Paper feeding and delivering capacities are all for 80gsm paper.

High paper Processing Ability to handle a Wide Range of Paper Types

bizhub PRESS C1100/C1085 has a high level of paper compatibility, making it possible to reduce damage to paper caused, for example, by heat or conveyance. For paper weights of 55 - 350gsm, bizhub PRESS C1100/C1085 supports a wide range of paper sizes from postcard size to 330 x 487mm. And can accommodate market needs for special printing with ease.

*Note: 80-350gsm for coated paper

High Level of Paper Compatibility

Konica Minolta has developed a new fusing system to enhance media handling capabilities. Conveyance reliability has been enhanced by incorporating a new inlet roller and fusing belt steering mechanism in the air blow fusing separation unit, improving conveyance of paper ranging from thin to thick types and making it possible to meet the high-variety needs of printing on demand.

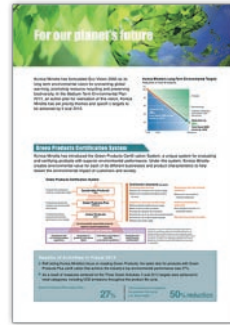
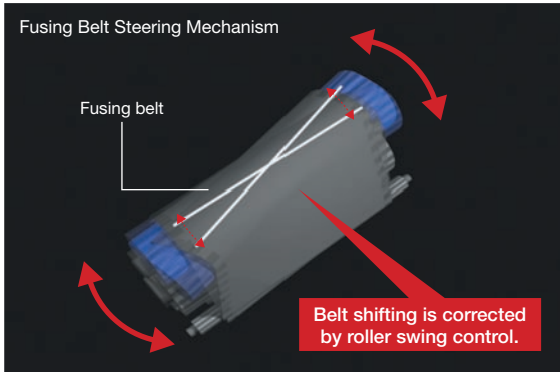

● Corporate reports



● Flyers and posters

High Image Positioning Accuracy

The high-precision registration unit, combining the existing paper skew detection/auto-correction mechanism with an interim roller nip release mechanism and a registration unit skew correction mechanism enables realisation of high front-to-back registration accuracy.

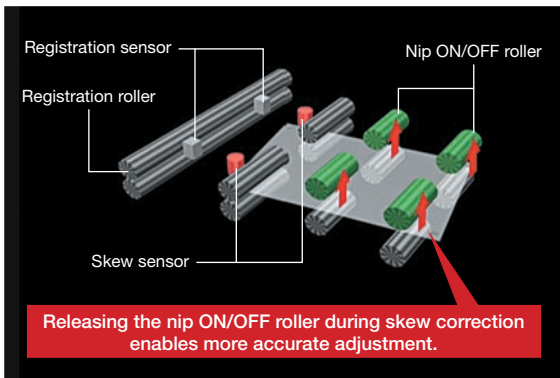

● Package samples

Printing Area that makes effective Use of Paper

bizhub PRESS C1100/C1085 accommodates paper size up to a maximum of 330 x 487mm. Capable of handling a maximum printing area of 321 x 480mm, bizhub PRESS C1100/C1085 is capable of A3-size printing with crop marks, needless to say, and also A4 size 2-up printing with crop marks.

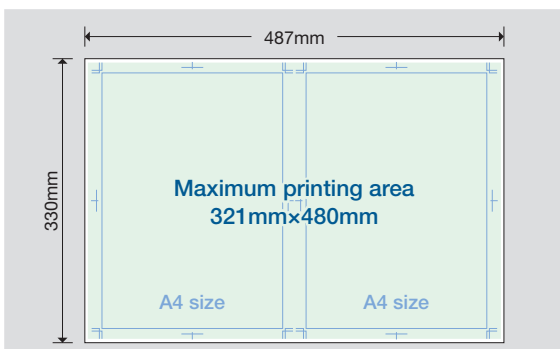

● Shop cards



● Menus



● Photo books



● Personalised calendars

Stable high Image Quality

Technologies that maintain stable high quality significantly contribute to business expansion. Capable of performing tasks traditionally deemed to be difficult including accurate reproduction of skin tone in facial photographs and beautifully reproducing details such as texture, bizhub PRESS C1100/C1085 provides stable image quality. Even the jobs making severe demands on image quality no longer need to be outsourced for offset printing.

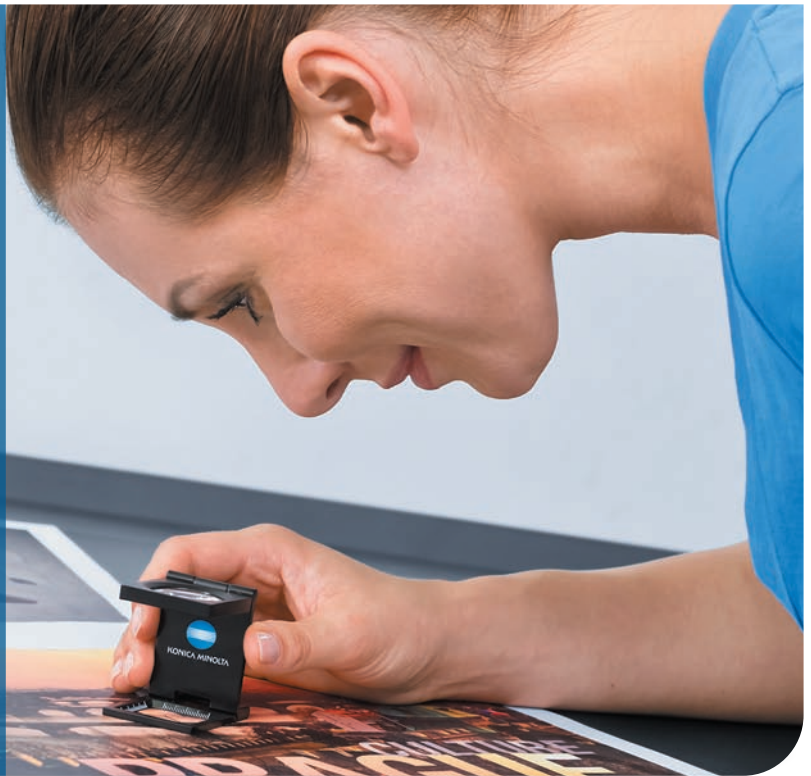

Established high Image Quality realised by Unique Technologies

Image quality is an essential element in the quality of printed matter. Utilising all of the unique technologies built by Konica Minolta at the very front line of on-demand printing, bizhub PRESS C1100/C1085 provides image quality to give users business advantages.

Coverage of ISO coated and Japan Color Gamuts

Adoption of Simitri HD^E Toner with its 3-dimensional hybrid structure expands the colour gamut at the same time as reducing the amount of toner used and ensures coverage of ISO coated and Japan Color gamuts. bizhub PRESS C1100/C1085 is capable of expressing colours equivalent to those of offset machines to meet the detailed requirements of clients.

■ Comparison of a*-b* chromaticity diagrams

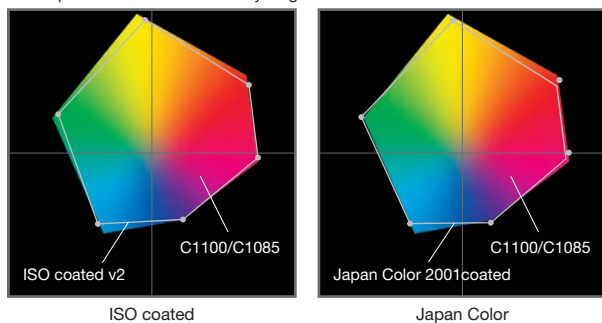

Simitri HD^E Toner

bizhub PRESS C1100/C1085 incorporates Simitri HD^E Toner, a newly-developed toner that realises improved image quality and energy-saving performance. The 3-dimensional structure that contains functional polymers ensures a high level of compatibility with all types of media and enables realisation of ideal natural textures. In addition, it requires only a small amount of heat for fusion, contributing significantly to reductions in power consumption.

■ Toner particles with 3D hybrid structure

Colourant

Improved colour reproducibility in red region and fade resistance. Enhanced half tone and skin tone quality thanks to improved granularity.

Functional polymer

Produces an effect that improves image quality and reduces energy use. Also allows high-speed processing.

Sharp melt wax

Produces an effect that improves image quality and reduces energy use.

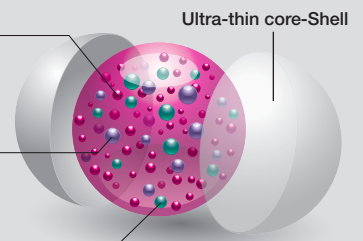

S.E.A.D.IV

Konica Minolta's unique cutting-edge image processing technology. High image quality taking optimum advantage of engine characteristics is achieved through utilising to the maximum of image processing, formation and developing systems.

Flexible Screen Processing

Varied screens are mounted to enable the achievement of suitable printing quality matched to the printing data content.

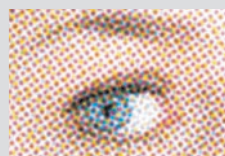

Dot190 (Default)



FM1



Precise Outline Processing

Realisation of appropriate reproduction through line-thinning to reduce character thickness and outline character background contour processing. The line-thinning adjustment range has been significantly expanded.

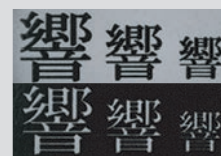

Without line-thinning process

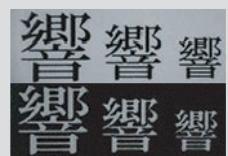

With line-thinning process

Minimisation of Colour Variance to provide Stable high-quality Images

Problems like colour shift occurring by the environment and printing processes, and miss-printing caused by conveyance problem, can lead to loss of orders and late deliveries. With a wide range of functions dedicated to the pursuit of stability, bizhub PRESS C1100/C1085 offers solutions to such problems.

Maintain High Productivity and Realisation of stable Tone Control

The high-precision IDC sensor performs precise auto-calibration in real time, enabling control of image stability (homogeneity). Even in high-volume printing, uniform printing quality is assured and with no reduction in productivity.

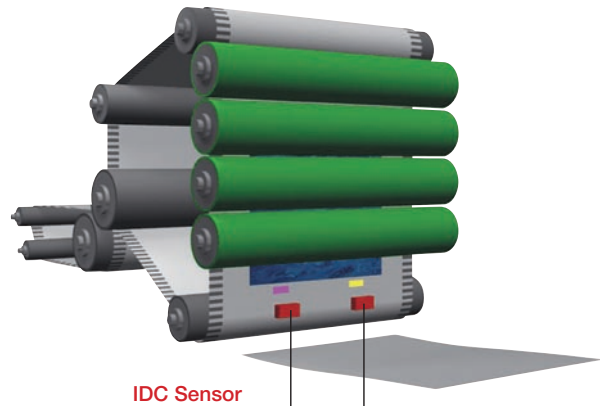

Suppress colour shift by maintaining main body internal temperature stable.

A cooling fan applies air in the main body to maintain the temperature at a constant level to realise the stabilisation of high image quality.

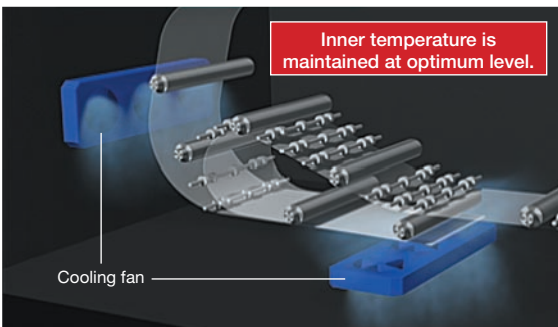

High-quality Images and Characters and precise Depiction of thin Lines

S.E.A.D.IV is an evolved image processing technology that enables reproduction down to fine details. Dot position control (DPC) is applied to control left, right and center dotting points for each individual pixel and 1200dpi processing is performed to realise a resolution approximately three times greater (equivalent to 3600dpi). Needless to say, this technology can reduce fattening of line or outline fonts, but it can also perform screen processing to enable faithful reproduction of gradations as in the original data.



High-precision Density Adjustment Mechanism matched to the Paper

A density sensor and colour feedback system that uses a new algorithm are mounted in the Relay Unit [RU-511]*. The unit is capable of measurement of not only CMYK, but also secondary colours (RGB). The performance of adjustments matched to the paper enables realisation of accurate colour management and stability. *Optional

■ Colour Feedback System

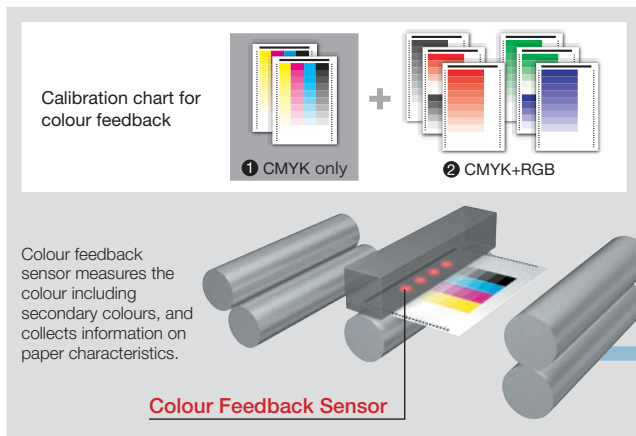

Work efficiency-enhancing Operation

Operation at the stage before output affects both quality and delivery. A rational, highly-efficient workflow that reduces the number of man-hours needs to be built to enable effective operation.



The speed and efficiency with which quality that will satisfy even the most discriminating clients are critical. In addition to output performance, operational capabilities are extremely important. bizhub PRESS C1100/C1085 is prepared with Konica Minolta own developed print controller with high affinity with the engine and Fiery print server. Conforming to the sophisticated management to realise offset printing-equivalent colour management.

Konica Minolta Image Controller [IC-602C]

*Optional

Main Body Control Panel Job Management and Editing

Capable of intuitive and efficient management. The outstanding operability provides the ability to edit elements such as job tickets and pages. Furthermore, tone curves can be adjusted using the same operations as Color Centro. PC-equivalent usability can be realised simply by connecting a USB mouse to the main body.



APPE2.6 as Standard

Standard with Adobe's APPE 2.6 (Adobe PDF Print Engine 2.6). APPE2.6 directly processes PDF files without having to access a printer driver for an appropriate transparent effect.



Original data PDF data with translucent images in various places.



Output result with APPE The translucent images are correctly processed as intended by the user.



Processing with CPSI The translucent images are incorrectly reproduced. The output is not what the user intended for.

Color Centro Ver2.0 (Colour Management Utility)

Colour management software as standard. Exact Color that performs high-precision 3D calibration, realising a major improvement in colour adjustment capability over conventional 1D calibration. Work, editing, settings and other tasks relating to colours matched to the main body such as colour adjustments, colour profile creation and simulations can be performed.

Comparison of Colour Adjusting Ability of Exact Color and 1D Calibration

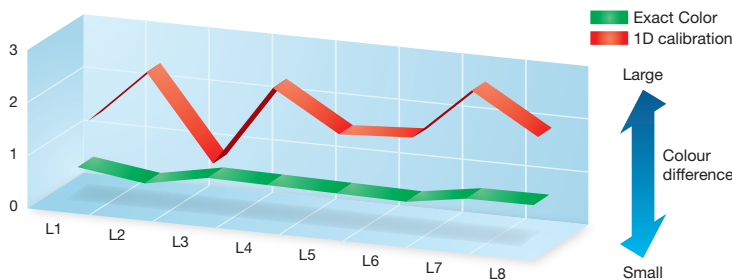

Horizontal axis (L1-L8): Environment in which colour fluctuations occur due to factors such as climatic changes
Vertical axis (Colour difference ΔE): Colours in standard environment and colour differences in envisaged environments

High-precision Spectral Densitometer



Konica Minolta's high-precision spectral densitometer FD-5BT* can be used to perform tasks such as ICC profile creation and calibration. In addition, FD-5BT can also be used as a stand-alone densitometer with display on the CTP printing shop floor.

*Optional

Job Centro Ver2.0 (Job Management Utility)

Enables job management with outstanding interface even with PCs. Elements such as indicators and thumbnail display have been incorporated into the screen configuration to realise enhanced operability and enable improved operating efficiency.

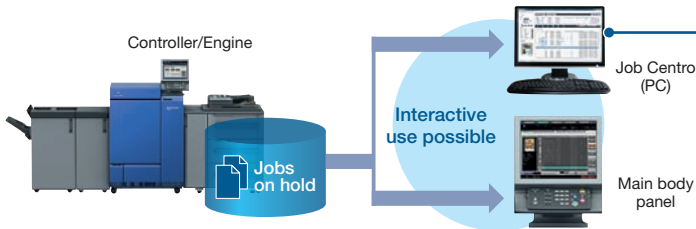

- High affinity with elements such the main body panel and printer driver.
- Realisation of seamless job management.
- Color Centro can be activated from the same screen.

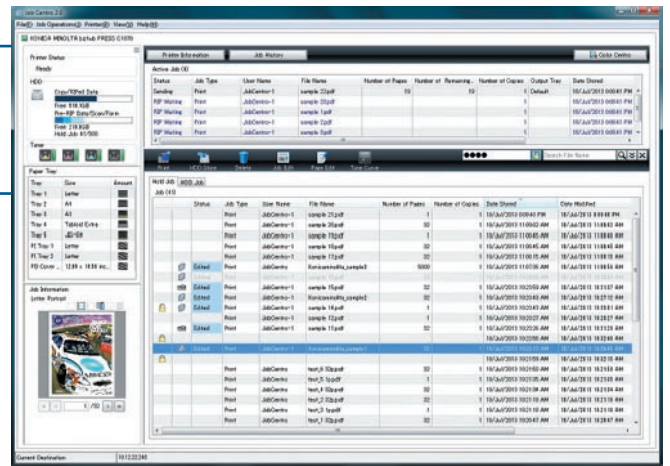

Seamless Offset Printing connectivity through JDF Compatibility

Compatible with JDF, a format for the display and transfer of jobs between printing processes. Interactive connectivity with major CTP workflow RIPs such as APOGEE, EQUIOS and Prinergy* makes it possible for the operator to use familiar CTP workflow RIPs without

making changes, enabling the construction of a hybrid workflow with seamless connectivity to offset printer. As a result, offset printing options are to include digital printing, enabling flexible handling.

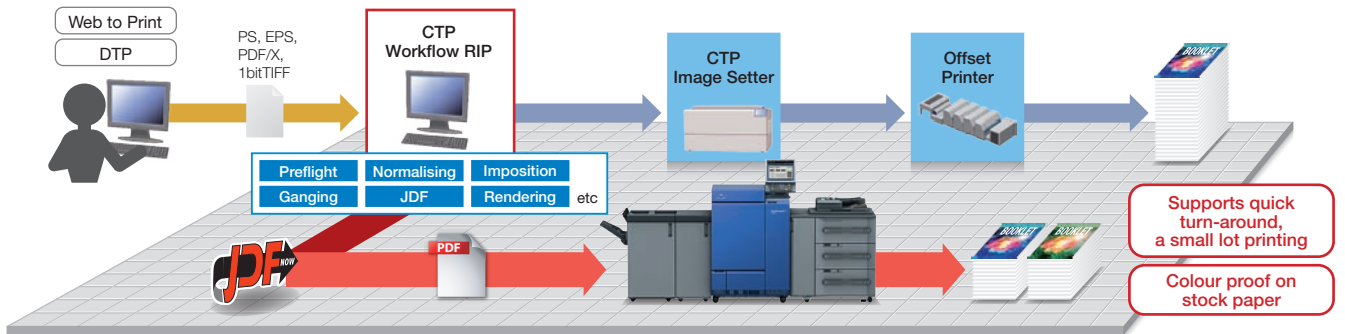

* "APOGEE" is a CTP workflow RIP from Agfa-Gevaert N.V, "EQUIOS" from Dainippon Screen Mfg. Co., Ltd., "Prinergy" from Eastman Kodak Company.

Fiery Print Server [IC-308]

Optional

High-speed Processing and High Image Quality

Realisation of high-speed processing compatible with a print engine capable of 1200 dpi x 8-bit ripping and printing speed of 100ppm (A4 long edge feed)*. In addition, a wide choice of colour profiles enables freedom of colour management.

*For C1100 (C1085: 85 ppm)

With APPE2.5

APPE 2.5 (Adobe PDF Print Engine 2.5) that supports transparent effect processing of PDF files as standard.

Colour Management

IC-308 performs colour management for each CMYK, RGB and spot colour space irrespective of the application or file format, making it ideal for colour management matched to purposes such as proofing and production of final deliverables.



Command WorkStation 5

Efficiently manages jobs from a PC on the Job Center and Device Center screens.

Job Center

Integrates all job management functions.

- Intuitive operation through drag and drop function.
- Provides an understanding of jobs and server information on the same screen.
- The tool bar can be customised to match functions used.
- Enables full-screen preview of jobs before and after RIP processing.

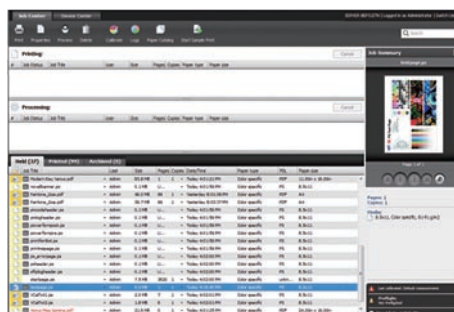

Device Center

Aggregates server setting functions on a single screen.

- Profile simulations can be set freely using intuitive colour setting tools.
- A paper catalogue can be mounted and tray settings made from either the main body or the controller.
- With efficient job management functions.

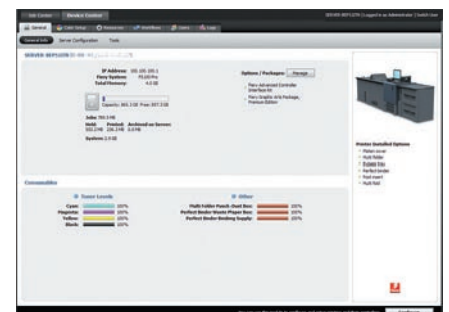

Achievement of both Labor Saving and High Added Value

The work of bizhub PRESS C1100/C1085 does not end with printing. Systems can be built to efficiently realise optimum added value and product differentiation.



Diversifying market needs have created a demand for a wide range of output formats. bizhub PRESS C1100/C1085 is furnished with diverse expansion options with outstanding operability to enable the realisation of high-quality high variety in-line finishing. Post-processing that has been outsourced in the past can now be performed through an in-house integrated production process to create added values on the cost and delivery fronts, thus realising differentiation competitors.

All-in-one finisher [FS-532]

*Optional

FS-532 stapling finisher with staple cutter provides stapling for up to 100 sheets*1 for beautiful finishes regardless of the number of sheets through enhanced paper output consistency and a refined paper path. And a choice of three sub-options can be fitted to expand the system when required. * Stapling for up to 50 sheets for A3 paper.

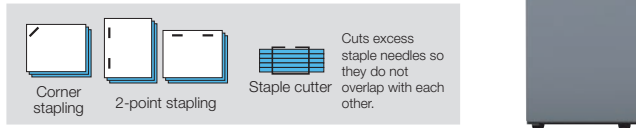

Expansion Options

Saddle stitcher [SD-510]

Use for saddle stitching, multi-letter-fold and centre-fold.

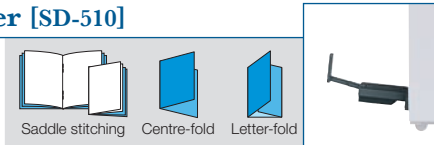

Punch Kit [PK-522]

Two- to four-hole punching for paper up to 300 gsm.

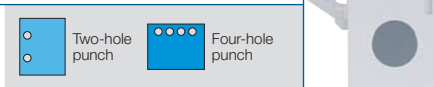

Post Inserter* [PI-502]

Add cover sheets and insertion sheets. Includes settings for two types of paper.

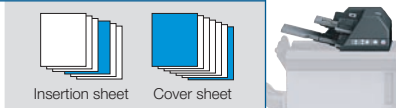

* Mount Kit (MK-732) required for installation.
* Some options may not be installed, depending on the combination of the options.

Multi-folding unit [FD-503]

*Optional

FD-503 provides a variety of folding functions, including centre-fold, letter-fold-in, letter-fold-out, double-parallel, Z-fold and gate-fold for creating materials such as direct mailings, as well as two or three-hole punching. A paper inserter for setting two types of paper is also equipped.

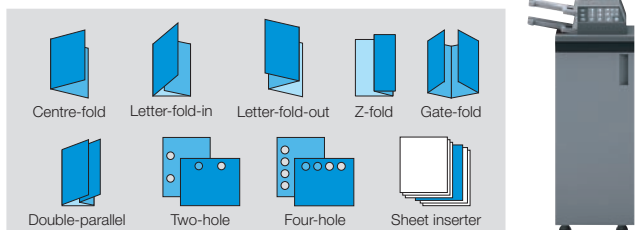

Saddle Stitcher [SD-506]

*Optional

Effective for manuals and catalogues in small lots, SD-506 creates booklets of up to 50 sheets (200 pages). And the saddle-stitching system increases folding strength and accuracy, reducing paper offset during binding. In addition to multi-centre-fold and multi-tri-fold, a trimming function for creating clean-cut booklets is standard equipped to streamline post-processing tasks including bookbinding.



Perfect Binder [PB-503]

*Optional

Perfectly binds up to 300 sheets (600 pages) or up to 30 mm thick. Cardstock up to 216 gsm* can be used for the cover, and inline printing and gluing is also available. Advanced paper alignment realises clean binding that eliminates three-way trimming, along with high productivity. In addition, books are automatically loaded onto the cart when finished.

* Max. 91 gsm for the inner pages when using a cover.

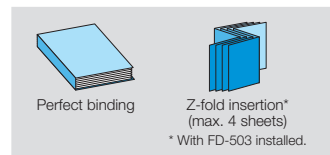

Large capacity stacker [LS-506]

*Optional

The LS-506 is designed to streamline operations with a capacity for 5,000 sheets and includes a cart. Up to two units can be installed side-by-side for a total capacity of 10,000 sheets, and finished documents can be taken out with the cart for easy transport to the next step. A sample ejection function allows quality checking to be made during large volume printing.



Improved Usability

Simply achieving high processing capabilities, paper handling abilities and image quality are not enough. All of these elements must be furnished with simple operability to enable the realisation of outstanding work efficiency through synergy.



bizhub PRESS
C1100

The ideal workflow in the printing business enables the high-speed finishing of large volumes of high-quality printed matter simply by transferring data to the printer. By minimising the need to stop the printer to make adjustments to complicated settings for elements such as daily maintenance, colour check tools, job management and profile creation that used to be required, bizhub PRESS C1100/C1085 contributes to major improvements in availability and productivity.

Intuitive Processing Operation

Information on items such as how to handle paper jams are shown in easy-to-understand format through graphical UI and messages. Even first-time users can resolve problems without stress.

Intuitive Print Job Management Operation

A common interface is used by the main body panel and printer driver screen to realise simple job management through integrated control of the main body and controller.

Enhanced Management

bizhub PRESS C1100/C1085 incorporates "Exact Color," an original high-precision calibration software. In addition to conventional 1D calibration, 3D calibration is also provided to ensure reduced colour differences, even in environments where colour fluctuations may occur, and enables adjustments including colour balancing of intermediate and mixed colours.

Compliance with diverse Paper Types and Paper Profile Function

500 paper types can be registered in advance to achieve major reductions in the time taken for adjustments to handle job changes.



System Overview

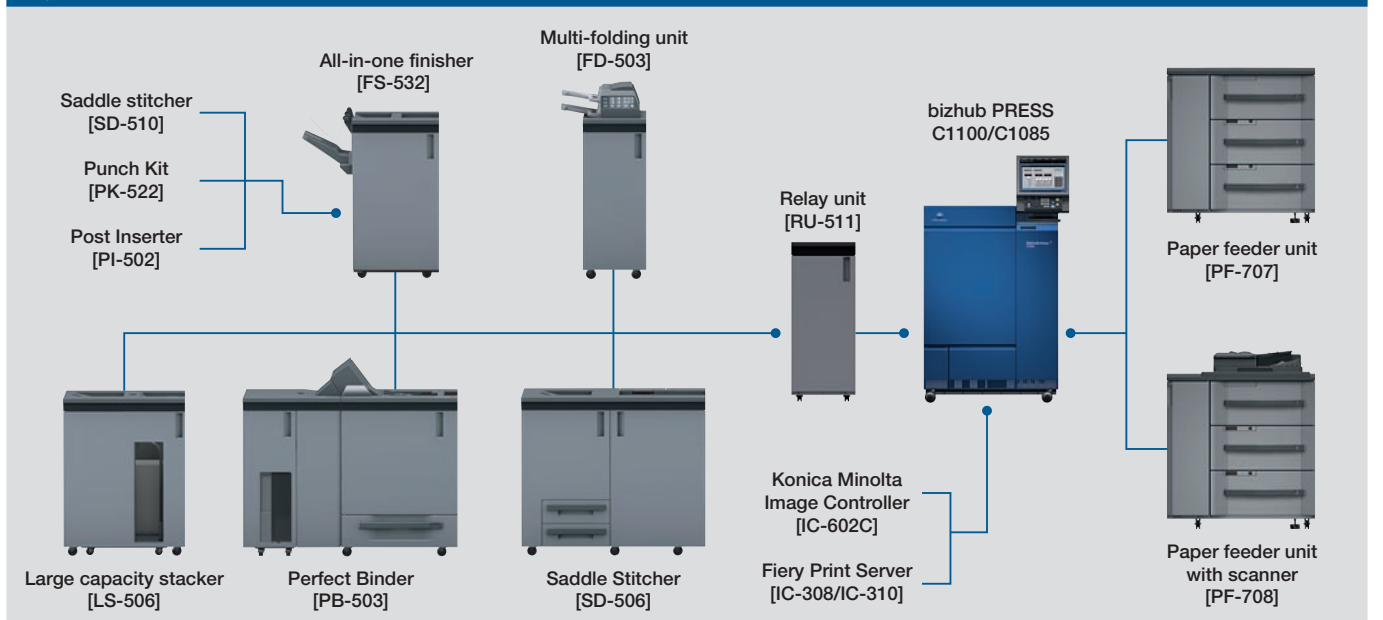

Specification

bizhub PRESS C1100/C1085 General Specifications

Main Unit

Model Name	bizhub PRESS C1100	bizhub PRESS C1085
Type	Console	
Colour Support	Full colour	
Writing Resolution	1200 (3600dpi equivalent) × 1200dpi	
Gradation	8bit/256 levels	
CPU	Core i5 2400 3.1GHz	
Memory	4GB	
Max. Printing Area	321×480mm	
Paper Size	SRA3, SRA4, A3, B4, A4, B5, A5, B6 landscape, A6 portrait, postcard, Irregular sizes (max.: 330×487mm, min.: 100×140mm)	
Image Loss	Top edge: 4mm or less, bottom edge: 4.5mm or less, right/left edges: 3mm or less Note: for 200gsm or thicker paper, top edge: 6mm or less, bottom edge: 7mm or less, sides: 6mm or less	
Warm-up Time	480 sec or less (at room temp 20°C, rated power supply)	
Continuous Print Speed	100 sheets/min (A4 landscape)	85 sheets/min (A4 landscape)
Full Colour/Black & White	53 sheets/min (A3)	46 sheets/min (A3)
Paper Weight	55gsm to 350gsm	
Power Requirements	Inch : AC208 to 240V 24A 60Hz Metric : AC220 to 240V 25A, 50Hz / 60 Hz	
Max. Power Consumption	Inch: 5,760W or less (Main body only) Metric: 6,000W or less (Main body only)	
Dimensions (W x D x H)	900×950×1,319mm (Main unit only, control panel, dust vacuum box, working table, rear duct not included)	
Work Space	Rear: 500mm or more, sides: 100mm or more work space required	
Weight	Approx. 430kg	

bizhub PRESS C1100 / C1085



Model shown is C1100/C1085 with options.



For more information please visit the bizhub Web site at

http://www.biz.konicaminolta.com/production/c1100_c1085/index.html



Product appearance, configuration and/or specifications are subject to change without notice.

This product is not available for some countries or regions.

The KONICA MINOLTA logo, symbol marks, Giving Shape to Ideas, bizhub PRESS, Simitri HDE, S.E.A.D. are registered trademarks or trademarks of KONICA MINOLTA, INC.

* Japan Color is registered trademark of The Japanese Society of Printing Science and Technology and Japan Printing Machinery Association.

* JDF, JDF logo are registered trademarks of CIP4 Organization.

* Fiery, Command WorkStation are registered trademarks or trademarks of Electronics For Imaging, Inc.

* All other brand and product names are the registered trademarks or trademarks of the respective companies to which they belong.

* Due to printing, the colouring of the product as it appears in this catalogue may differ from that of the actual product.

* The operation panels shown in this catalogue are synthetic simulations.

ISO15408 (EAL Level 3) Certification (Currently under application)

These products comply with the security requirements of ISO15408 (EAL Level 3).

* The ISO 15408 certification applies only to IT security capabilities. This certification is NOT a product guarantee.



From consulting, system design, to operations, Konica Minolta offers total support to optimise your office output environment.

<http://www.biz.konicaminolta.com/services/ops>

Requirements for safe use

- Please read and follow the instruction manual to ensure safe operation.
- Only operate using appropriate power supply and voltage.
- Connecting the earth wire to an inappropriate place may cause explosion or electric shock. Please connect accordingly (Taiwan and the Philippines only).

KONICA MINOLTA, INC.

2-7-2 Marunouchi Chiyoda-ku, Tokyo, Japan
<http://www.biz.konicaminolta.com>

9251-3225-01 Printed in Japan